

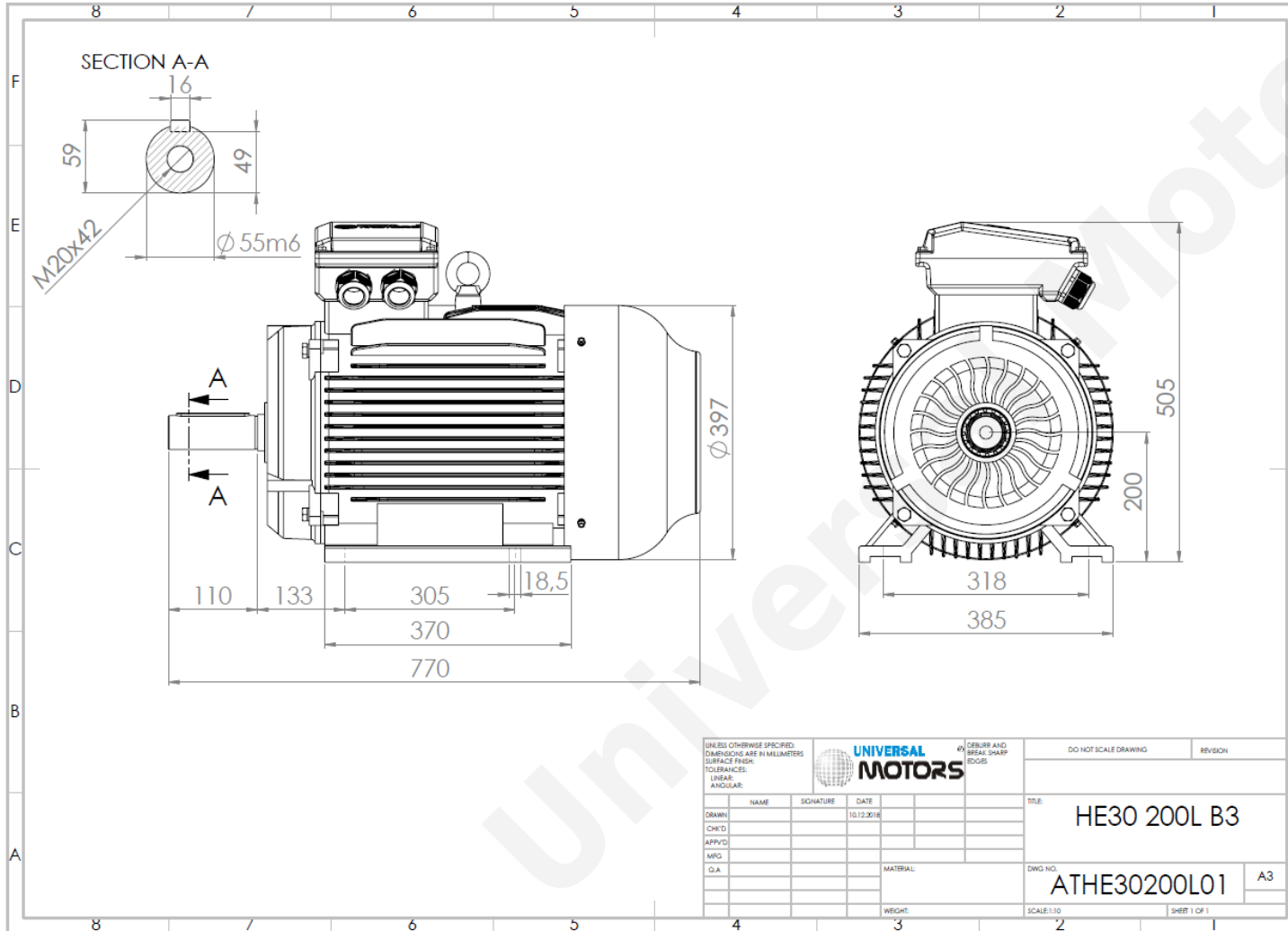

TECHNICAL DATA

Three Phase Electric Motors - Cast Iron Frame
 HE30 200 L-6 IE2
 22 kW / 30 Cv
 980 RPM



Motor type:	HE30 200 L-6 IE2
Output:	22 kW / 30 Cv
Speed (min ⁻¹):	980 RPM
Frequency:	50 Hz
Voltage:	400 V
Current:	42.6 A
Power factor (Cos Ø):	0.82
Poles:	6
Insulation class:	F
Temperature rise Class:	B
Efficiency 50%:	90.5 %
Efficiency 75%:	91.3 %
Efficiency 100%:	90.9 %
Torque:	214 N.m
Tstarting/Tnominal:	2.0
Istarting/Inominal:	7.3
Tmaximum/Tnominal:	2.1
Noise:	63 Db(A)
Weight:	253 Kg
Bearing DE:	6312 C3
Bearing NDE:	6312 C3

Regime - S1

Altitude - 1000m

Environment Temperature - 40°C

CONTACTS:

UNIVERSAL MOTORS Tel: +351 252 299 080
 Rua de São Brás,745 Fax: +351 252 299 089
 4480-782 VILA DO CONDE Mail: geral@universalmotors.pt

* References applied only in the UK